

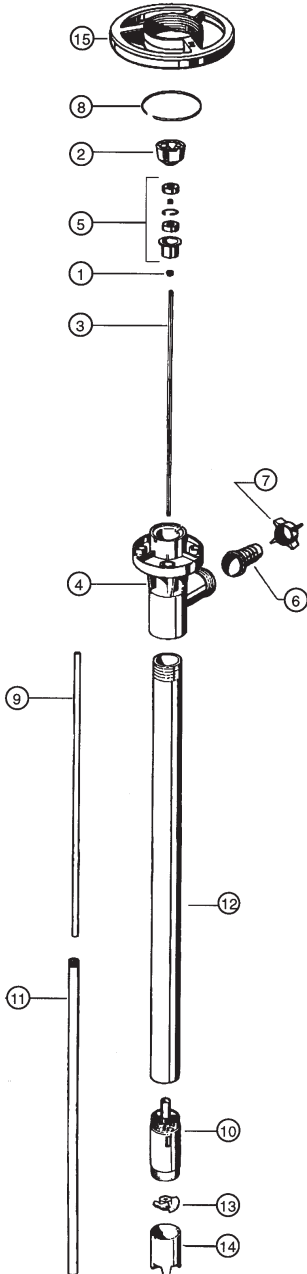

# HIGH TEMPERATURE PUMP TUBE SP-PHT SERIES



ITEM NO.	DESCRIPTION	PART NUMBER
1	V-seal - TFE	4000
2*	Pump coupling	1004
3	Drive shaft	27" (700 mm) 1543 39" (1000 mm) 1544 47" (1200 mm) 1545 60" (1400 mm) 1546 72" (1800 mm) 1547
4	Discharge housing	
5*	Bearing unit assembled - 2 each	6028
	Viton shielded bearings, spacer, snap ring, bearing can	1038
6	Hose barb,	3/4" (22 mm) 6051 1" (25 mm) 6082
7	Wing nut	6106
8*	Snap ring	1508
9	Guide sleeve - TFE	27", 39", 47" 1514 60", 72" 1661
10	Pump housing includes carbon bushing	6524
11	Inner tube,	27" (700 mm) 6600 39" (1000 mm) 6601 47" (1200 mm) 6602 60" (1400 mm) 6615 72" (1800 mm) 6616
12	Outer tube,	27" (700 mm) 6604 39" (1000 mm) 6603 47" (1200 mm) 6605 60" (1400 mm) 6617 72" (1800 mm) 6618
13	Impeller	6608
	High pressure impeller	4608 HH
14	Pump foot	6609
	High pressure pump foot	6609 HH
15*	Hand wheel	1842

\* Parts interchangeable with all pump tubes.

**⚠ Polypropylene pumps should not be used to pump flammables.**